



## Installation Instructions

# Compact™ I/O 1769-IR6 RTD/resistance Input Module

### Inside

Module Overview.....	2
Module Installation.....	3
System Assembly.....	4
Mounting Expansion I/O.....	5
Replacing a Single Module within a System.....	7
Field Wiring Connections.....	8
I/O Memory Mapping.....	16
Specifications.....	19
Hazardous Location Considerations.....	22
Environnements dangereux.....	22
For More Information.....	23

## Module Overview

The 1769-IR6 module receives and stores digitally converted analog data from RTDs or other resistance inputs, such as potentiometers. The module supports connections from any combination of up to 6 RTDs or other resistance inputs. See the input specifications on page 20 for supported RTD and resistance types, their associated temperature ranges, and the analog input signal ranges that each channel supports. Each of the 6 input channels is individually configurable for a specific input device and provides open- or short-circuit and over- or under-range indication.

## Hardware

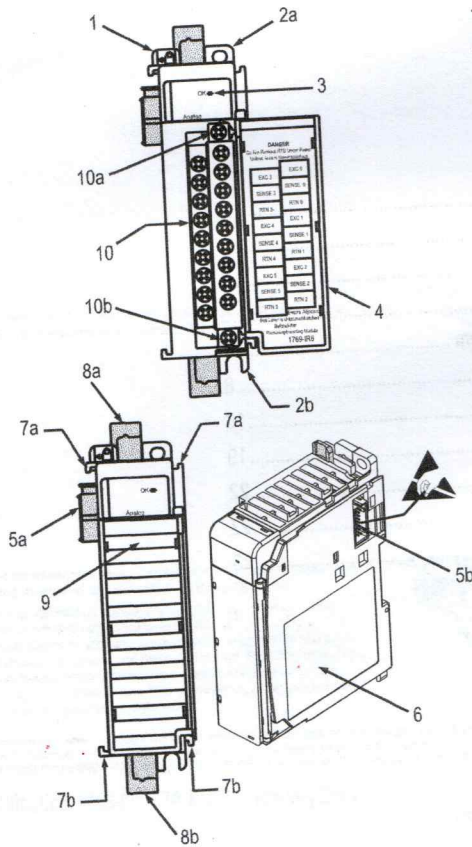

Item	Description
1	bus lever (with locking function)
2a	upper panel mounting tab
2b	lower panel mounting tab
3	module status LED
4	module door with terminal identification label
5a	movable bus connector with female pins
5b	stationary bus connector with male pins
6	nameplate label
7a	upper tongue-and-groove slots
7b	lower tongue-and-groove slots
8a	upper DIN rail latch
8b	lower DIN rail latch
9	write-on label (user ID tag)
10	removable terminal block (RTB) with finger-safe cover
10a	RTB upper retaining screw
10b	RTB lower retaining screw

## Module Installation

Compact I/O is suitable for use in an industrial environment when installed in accordance with these instructions. Specifically, this equipment is intended for use in clean, dry environments (Pollution degree 2<sup>(1)</sup>) and to circuits not exceeding Over Voltage Category II<sup>(2)</sup> (IEC 60664-1).<sup>(3)</sup>

## Prevent Electrostatic Discharge

### ATTENTION



Electrostatic discharge can damage integrated circuits or semiconductors if you touch bus connector pins or the terminal block. Follow these guidelines when you handle the module:

- Touch a grounded object to discharge static potential.
- Wear an approved wrist-strap grounding device.
- Do not touch the bus connector or connector pins.
- Do not touch circuit components inside the module.
- If available, use a static-safe work station.
- When not in use, keep the module in its static-shield box.

## Remove Power

### ATTENTION



Remove power before removing or inserting this module. When you remove or insert a module with power applied, an electrical arc may occur. An electrical arc can cause personal injury or property damage by:

- sending an erroneous signal to your system's field devices, causing unintended machine motion
- causing an explosion in a hazardous environment

Electrical arcing causes excessive wear to contacts on both the module and its mating connector. Worn contacts may create electrical resistance.

- (1) Pollution Degree 2 is an environment where, normally, only non-conductive pollution occurs except that occasionally a temporary conductivity caused by condensation shall be expected.
- (2) Over Voltage Category II is the load level section of the electrical distribution system. At this level transient voltages are controlled and do not exceed the impulse voltage capability of the product's insulation.
- (3) Pollution Degree 2 and Over Voltage Category II are International Electrotechnical Commission (IEC) designations.

## System Assembly

The module can be attached to the controller or an adjacent I/O module *before* or *after* mounting. For mounting instructions, see "Panel Mounting" on page 6, or "DIN Rail Mounting" on page 7. To work with a system that is already mounted, see "Replacing a Single Module within a System" on page 7.

The following procedure shows you how to assemble the Compact I/O system.

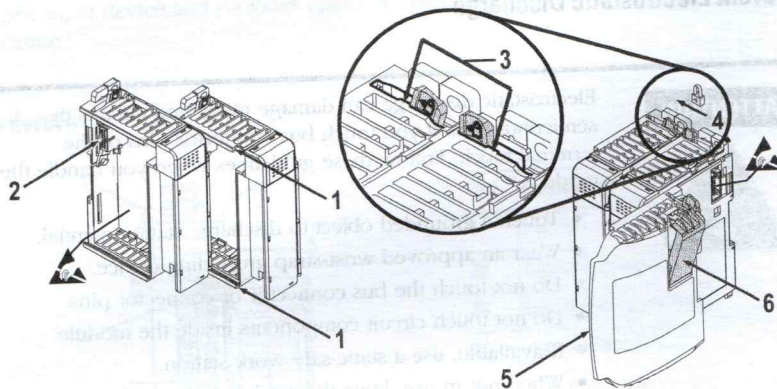

1. Disconnect power.
2. Check that the bus lever of the module to be installed is in the unlocked (fully right) position.
3. Use the upper and lower tongue-and-groove slots (1) to secure the modules together (or to a controller).
4. Move the module back along the tongue-and-groove slots until the bus connectors (2) line up with each other.
5. Push the bus lever back slightly to clear the positioning tab (3). Use your fingers or a small screwdriver.

- To allow communication between the controller and module, move the bus lever fully to the left (4) until it clicks. Ensure it is locked firmly in place.

**ATTENTION**



When attaching I/O modules, it is very important that the bus connectors are securely locked together to ensure proper electrical connection.

- Attach an end cap terminator (5) to the last module in the system by using the tongue-and-groove slots as before.
- Lock the end cap bus terminator (6).

**IMPORTANT**

A 1769-ECR or 1769-ECL right or left end cap (respectively) must be used to terminate the end of the communication bus.

**Mounting Expansion I/O**

**ATTENTION**



During panel or DIN rail mounting of all devices, be sure that all debris (metal chips, wire strands, etc.) is kept from falling into the module. Debris that falls into the module could cause damage on power up.

**Minimum Spacing**

Maintain spacing from enclosure walls, wireways, adjacent equipment, etc. Allow 50 mm (2 in.) of space on all sides for adequate ventilation, as shown:

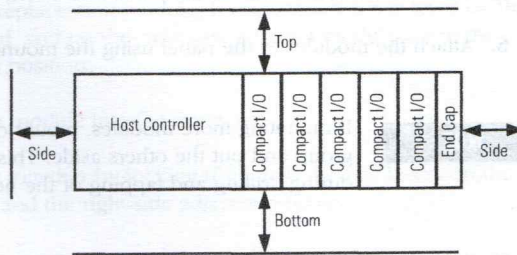

## Panel Mounting

Mount the module to a panel using two screws per module. Use M4 or #8 panhead screws. Mounting screws are required on every module.

### Panel Mounting Using the Dimensional Template

For more than 2 modules: (number of modules-1) X 35mm (1.38 in.)

Refer to host controller documentation for this dimension.

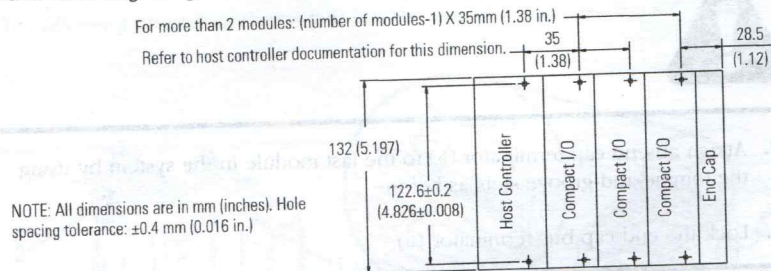

NOTE: All dimensions are in mm (inches). Hole spacing tolerance:  $\pm 0.4$  mm (0.016 in.)

### Panel Mounting Procedure Using Modules as a Template

The following procedure allows you to use the assembled modules as a template for drilling holes in the panel. If you have sophisticated panel mounting equipment, you can use the dimensional template provided on page 6. Due to module mounting hole tolerance, it is important to follow these procedures:

1. On a clean work surface, assemble no more than three modules.
2. Using the assembled modules as a template, carefully mark the center of all module-mounting holes on the panel.
3. Return the assembled modules to the clean work surface, including any previously mounted modules.
4. Drill and tap the mounting holes for the recommended M4 or #8 screw.
5. Place the modules back on the panel and check for proper hole alignment.
6. Attach the modules to the panel using the mounting screws.

#### NOTE

If mounting more modules, mount only the last one of this group and put the others aside. This reduces remounting time during drilling and tapping of the next group.

7. Repeat steps 1 to 6 for any remaining modules.

## DIN Rail Mounting

The module can be mounted using the following DIN rails: 35 x 7.5 mm (EN 50 022 - 35 x 7.5) or 35 x 15 mm (EN 50 022 - 35 x 15).

Before mounting the module on a DIN rail, close the DIN rail latches. Press the DIN rail mounting area of the module against the DIN rail. The latches will momentarily open and lock into place.

## Replacing a Single Module within a System

The module can be replaced while the system is mounted to a panel (or DIN rail). Follow these steps in order:

1. Remove power. See important note on page 3.
2. On the module to be removed, remove the upper and lower mounting screws from the module (or open the DIN latches using a flat-blade or phillips-style screwdriver).
3. Move the bus lever to the right to disconnect (unlock) the bus.
4. On the right-side adjacent module, move its bus lever to the right (unlock) to disconnect it from the module to be removed.
5. Gently slide the disconnected module forward. If you feel excessive resistance, check that the module has been disconnected from the bus and that both mounting screws have been removed (or DIN latches opened).

### NOTE

It may be necessary to rock the module slightly from front to back to remove it, or, in a panel-mounted system, to loosen the screws of adjacent modules.

6. Before installing the replacement module, be sure that the bus lever on the module to be installed, and on the right-side adjacent module are in the unlocked (fully right) position.
7. Slide the replacement module into the open slot.
8. Connect the modules together by locking (fully left) the bus levers on the replacement module and the right-side adjacent module.
9. Replace the mounting screws (or snap the module onto the DIN rail).

## Field Wiring Connections

### Grounding the Module

This product is intended to be mounted to a well-grounded mounting surface such as a metal panel. Additional grounding connections from the module's mounting tabs or DIN rail (if used), are not required unless the mounting surface cannot be grounded. Refer to *Industrial Automation Wiring and Grounding Guidelines*, Allen-Bradley publication 1770-4.1, for additional information.

### System Wiring Guidelines

Consider the following when wiring your system:

- Use Belden shielded, twisted-pair wire to ensure proper operation and high immunity to electrical noise. See "RTD Wiring Considerations".
- To limit noise, locate RTD and resistance device signal wires as far away as possible from power lines, load lines, and other sources of electrical noise, such as hard-contact switches, relays, and AC motor drives.
- Locate RTD modules away from other modules which generate a significant amount of heat, such as the 1769-IA16.
- Under normal conditions, the drain wire and shield junction should be connected to earth ground, via a panel or DIN rail mounting screw at the 1769-IR6 module end.
- Keep shield connection to ground as short as possible.
- To ensure optimum accuracy, limit overall cable impedance by keeping your cable as short as possible. Locate the I/O system as close to your sensors or actuators as your application will permit. See the table on the following page.



## RTD Wiring Considerations

Since the operating principle of the RTD module is based on the measurement of resistance, take special care when selecting your input cable. For 2-wire or 3-wire configurations, select a cable that has a consistent impedance throughout its entire length.

Configuration	Recommended Cable
2-wire	Belden™ 9501 or equivalent
3-wire — less than 30.48 m (100ft.)	Belden™ 9533 or equivalent
3-wire — greater than 30.48 m (100 ft.) or high humidity conditions	Belden™ 83503 or equivalent

### IMPORTANT

The RTD module requires three wires to compensate for lead resistance error. We recommend that you do not use 2-wire RTDs if long cable runs are required, as it reduces the accuracy of the system. However, if a two-wire configuration is required, reduce the effect of the lead wire resistance by using a lower gauge wire for the cable (for example, use AWG #16 instead of AWG #24). The module's terminal block accepts two AWG #14 gauge wires.

When using a 3-wire configuration, the module compensates for resistance error due to lead wire length. For example, in a 3-wire configuration, the module reads the resistance due to the length of one of the wires and assumes that the resistance of the other wire is equal. If the resistances of the individual lead wires are much different, an error may exist. The closer the resistance values are to each other, the greater the amount of error is eliminated.

### IMPORTANT

To ensure temperature or resistance value accuracy, the resistance difference of the cable lead wires must be equal to or less than  $0.01\Omega$ .

To insure that the lead values match as closely as possible:

- Keep lead resistance as small as possible and less than  $25\Omega$ .
- Use quality cable that has a small tolerance impedance rating.
- Use a heavy-gauge lead wire which has less resistance per foot.

### RTD Wiring Configurations

For a 3-wire configuration, the module can compensate for a maximum cable length associated with an overall cable impedance of 25 ohms.

Three configurations of RTDs can be connected to the 1769-IR6 module:

- 2-wire RTD, which is composed of an RTD EXC (excitation) lead wire and a RTN (return) lead wire
- 3-wire RTD, which is composed of a Sense and 2 RTD lead wires (RTD EXC and RTN)
- 4-wire RTD, which is composed of a Sense and 2 RTD lead wires (RTD EXC and RTN). The second sense wire of a 4-wire RTD is left open.

#### 2-Wire RTD Configuration

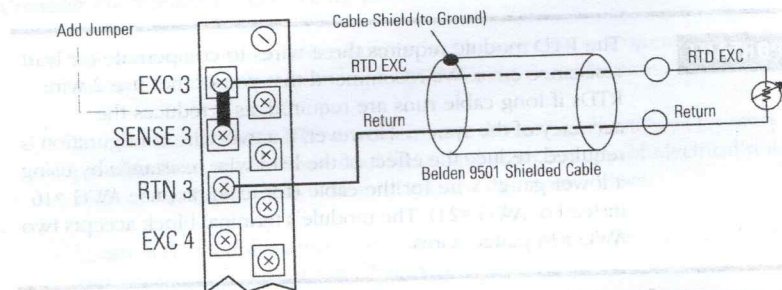

#### 3-Wire RTD Configuration

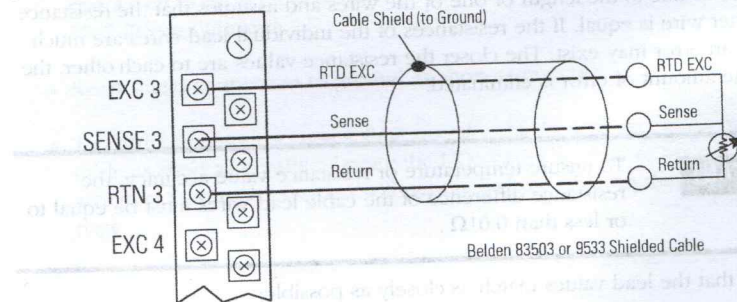

#### 4-Wire RTD Configuration

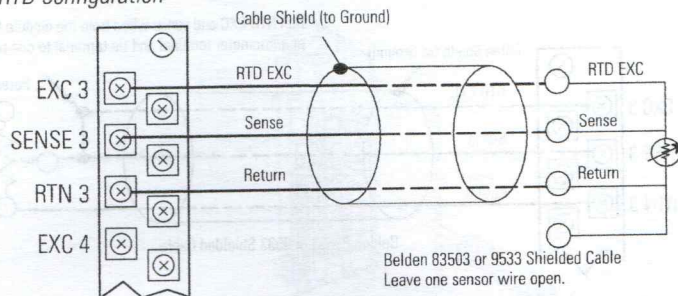

#### Wiring Resistance Devices (Potentiometers)

Potentiometer wiring requires the same type of cable as that for the RTD described on page 9. Potentiometers can be connected to the module as a 2-wire or 3-wire connection as shown below.

#### 2-Wire Potentiometer Interconnection

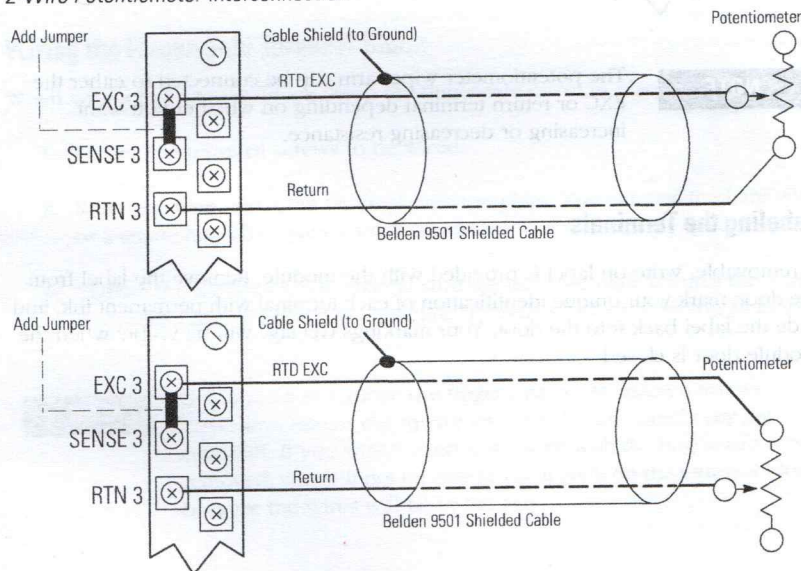
**NOTE**

The potentiometer wiper arm can be connected to either the EXC or return terminal, depending on whether you want increasing or decreasing resistance.

### 3-Wire Potentiometer Interconnection

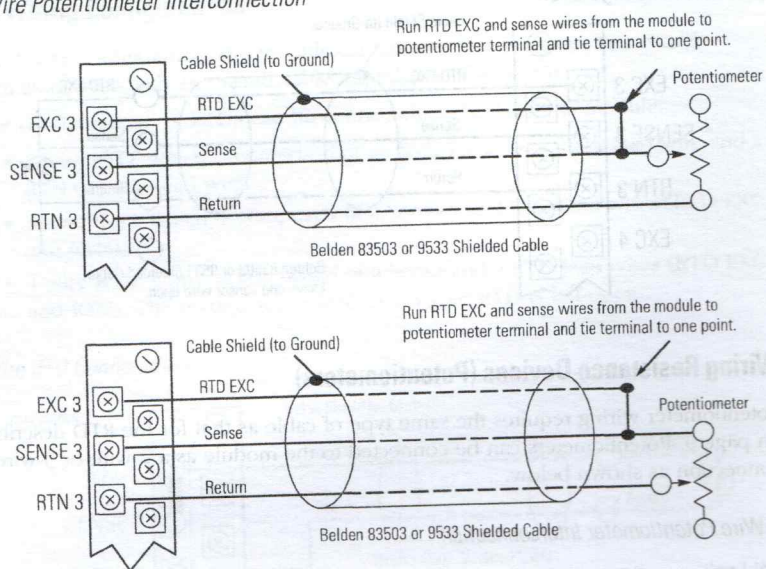

**NOTE**

The potentiometer wiper arm can be connected to either the EXC or return terminal depending on whether you want increasing or decreasing resistance.

### Labeling the Terminals

A removable, write-on label is provided with the module. Remove the label from the door, mark your unique identification of each terminal with permanent ink, and slide the label back into the door. Your markings (ID tag) will be visible when the module door is closed.

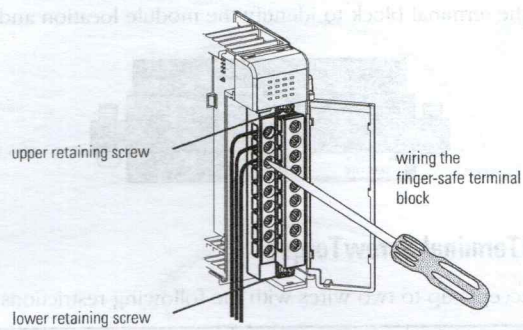

### Removing the Finger-Safe Terminal Block

To remove the terminal block, loosen the upper and lower retaining screws. The terminal block will back away from the module as you remove the screws. When replacing the terminal block, torque the retaining screws to 0.46 Nm (4.1 in-lbs).

### Wiring the Finger-Safe Terminal Block

When wiring the terminal block, keep the finger-safe cover in place.

1. Loosen the terminal screws to be wired.
2. Route the wire under the terminal pressure plate. You can use the bare wire or a spade lug. The terminals will accept a 6.35 mm (0.25 in.) spade lug.
3. Tighten the terminal screw making sure the pressure plate secures the wire. Recommended torque when tightening terminal screws is 0.68 Nm (6 in-lbs).

#### NOTE

If you need to remove the finger-safe cover, insert a screwdriver into one of the square wiring holes and gently pry the cover off. If you wire the terminal block with the finger-safe cover removed, you will not be able to put it back on the terminal block because the wires will be in the way.

If you remove the terminal block from the module, use the write-on label located on the side of the terminal block to identify the module location and type.



### Wire Size and Terminal Screw Torque

Each terminal accepts up to two wires with the following restrictions:

Wire Type		Wire Size	Terminal Screw Torque	Retaining Screw Torque
Solid	Cu-90°C (194°F)	#14 to #22 AWG	0.68 Nm (6 in-lbs)	0.46 Nm (4.1 in-lbs)
Stranded	Cu-90°C (194°F)	#16 to #22 AWG	0.68 Nm (6 in-lbs)	0.46 Nm (4.1 in-lbs)

### Wiring Input Devices to the 1769-IR6

**ATTENTION**



Be careful when stripping wires. Wire fragments that fall into a module could cause damage at power up. Once wiring is complete, ensure the module is free of all metal fragments.

After the module is properly installed, follow the wiring procedure below:

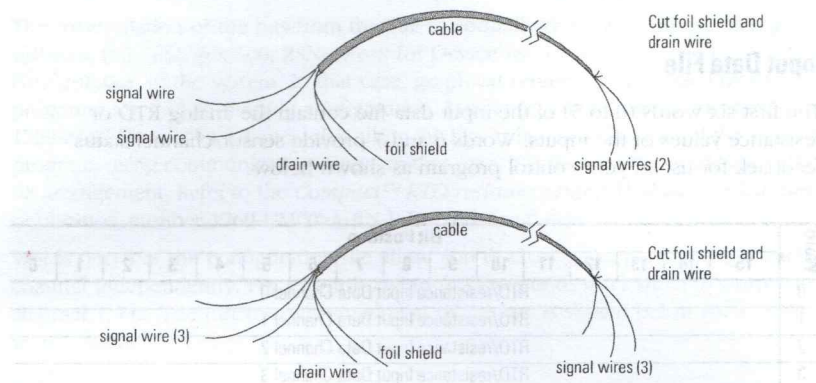

To wire your sensor to the module, follow these steps:

1. At each end of the cable, strip some casing to expose the individual wires.
2. Trim the signal wires to 2-inch lengths. Strip about 3/16 inch (5 mm) of insulation away to expose the end of the wire.
3. At one end of the cable, twist the drain wire and foil shield together, bend them away from the cable, and apply shrink wrap. Then earth ground at the preferred location based on the type of sensor you are using.
4. At the other end of the cable, cut the drain wire and foil shield back to the cable and apply shrink wrap.
5. Connect the signal wires to the module terminal block and input.
6. Repeat steps 1 through 5 for each channel on the module.

## I/O Memory Mapping

### Input Data File

The first six words (0 to 5) of the input data file contain the analog RTD or resistance values of the inputs. Words 6 and 7 provide sensor/channel status feedback for use in your control program as shown below.

Word	Bit Position															
	15	14	13	12	11	10	9	8	7	6	5	4	3	2	1	0
0	RTD/resistance Input Data Channel 0															
1	RTD/resistance Input Data Channel 1															
2	RTD/resistance Input Data Channel 2															
3	RTD/resistance Input Data Channel 3															
4	RTD/resistance Input Data Channel 4															
5	RTD/resistance Input Data Channel 5															
6	Not Used	OC5	OC4	OC3	OC2	OC1	OC0	Not Used	S5	S4	S3	S2	S1	S0		
7	U0	U0	U1	U1	U2	U2	U3	U3	U4	U4	U5	U5	Not Used			

Word 6 and 7 status bits are defined as follows:

- **Sx** = General status bit for channels 0 through 5. This bit is set (1) when an error (over- or under-range, open-circuit, or input data not valid) exists for that channel. An input data not valid condition is determined by the user program. This condition occurs when the first analog-to-digital conversion is still in progress at power-up or after a new configuration has been sent to the module. Refer to the *RTD/resistance Input Module User Manual*, publication number 1769-UM005A-EN-P, for details.
- **OCx** = Open-circuit detection bit for channels 0 through 5. These bits are set (1) when either an open or shorted input for RTD inputs or an open input for resistance inputs is detected.

#### NOTE

Short-circuit detection for resistance inputs is not indicated because 0 is a valid number.

- **Ux** = Under-range flag bits for channels 0 through 5, using RTD inputs only. These bits can be used in the control program for error detection. There is no under-range error for a direct resistance input, because 0 is a valid number.
- **Ox** = Over-range flag bits for channels 0 through 5, using either RTD or resistance inputs. These bits can be used in the control program for error detection.



## Configuration Data File

The manipulation of the bits from this file is normally done with programming software (e.g. RSLogix 500, RSNetwork for DeviceNet, etc.) during initial configuration of the system. In that case, graphical screens are provided by the programming tool to simplify configuration. However, some systems, like the 1769-ADN DeviceNet Adapter, also allow the bits to be altered as part of the control program, using communication rungs. In that case, it is necessary to understand the bit arrangement. Refer to the *Compact™ RTD/resistance Input Module User Manual*, publication number 1769-UM005A-EN-P for additional details.

Words 0 to 5 of the configuration file allow you to change the parameters of each channel independently. For example, word 0 corresponds to channel 0, word 1 to channel 1, etc. The functional arrangement of the bits is shown below for a single word/channel.

To Select		Make these bit settings															
		15	14	13	12	11	10	9	8	7	6	5	4	3	2	1	0
Filter Frequency	10 Hz														1	1	0
	60 Hz														0	0	0
	50 Hz														0	0	1
	250Hz														0	1	1
	500 Hz														1	0	0
	1 kHz														1	0	1
Excitation Current	1.0 mA													0			
	0.5 mA													1			
Cyclic Lead Compensation	Enable												0				
	Disable												1				
Open-circuit/ Broken Input	Upscale										0	0					
	Downscale										0	1					
	Last State										1	0					
	Zero										1	1					
Temperature Units Mode	°C									0							
	°F									1							

To Select		Make these bit settings															
		15	14	13	12	11	10	9	8	7	6	5	4	3	2	1	0
Input/Sensor Type	100Ω Pt 385					0	0	0	0								
	200Ω Pt 385					0	0	0	1								
	500Ω Pt 385					0	0	1	0								
	1000Ω Pt 385					0	0	1	1								
	100Ω Pt 3916					0	1	0	0								
	200Ω Pt 3916					0	1	0	1								
	500Ω Pt 3916					0	1	1	0								
	1000Ω Pt 3916					0	1	1	1								
	10Ω Cu 426					1	0	0	0								
	120Ω Ni 618					1	0	0	1								
	120Ω Ni 672					1	0	1	0								
	604Ω NiFe 518					1	0	1	1								
	150Ω					1	1	0	0								
	500Ω					1	1	0	1								
	1000Ω					1	1	1	0								
	3000Ω					1	1	1	1								
	Data Format	Raw/Proportional		0	0	0											
Engineering Units			0	0	1												
Engr. Units X 10			1	0	0												
Scaled-for-PID			0	1	0												
Percent Range			0	1	1												
Enable Channel	Enable	1															
	Disable	0															

### Module Configuration Word

Word 6 of the configuration data file contains the Enable/Disable Cyclic Calibration bit as shown in the table below.

To Select		Make these bit settings															
		15	14	13	12	11	10	9	8	7	6	5	4	3	2	1	0
Enable/Disable Cyclic Calibration	Enabled <sup>(1)</sup>																0
	Disabled																1

(1) When enabled, an autocalibration cycle is performed on all enabled channels every 5 minutes.

### Spare/Replacement Parts for 1769-IR6

- Terminal Block: 1769-RTBN18 (1 per kit)
- Door: 1769-RD (2 per kit)

## Specifications

### General Specifications

Specification	Value
Dimensions	118 mm (height) x 87 mm (depth) x 35 mm (width) height including mounting tabs is 138 mm 4.65 in. (height) x 3.43 in (depth) x 1.38 in (width) height including mounting tabs is 5.43 in.
Approximate Shipping Weight (with carton)	276g (0.61 lbs.)
Storage Temperature	-40°C to +85°C (-40°F to +185°F)
Operating Temperature	0°C to +60°C (32°F to +140°F)
Operating Humidity	5% to 95% non-condensing
Operating Altitude	2000 meters (6561 feet)
Vibration	Operating: 10 to 500 Hz, 5G, 0.030 in. peak-to-peak Relay Operation: 2G
Shock	Operating: 30G, 11 ms panel mounted (20G, 11 ms DIN rail mounted) Relay Operation: 7.5G panel mounted (5G DIN rail mounted) Non-Operating: 40G panel mounted (30G DIN rail mounted)
Agency Certification	<ul style="list-style-type: none"> <li>• C-UL certified (under CSA C22.2 No. 142)</li> <li>• UL 508 listed</li> <li>• CE compliant for all applicable directives</li> </ul>
Hazardous Environment Class	Class I, Division 2, Hazardous Location, Groups A, B, C, D (UL 1604, C-UL under CSA C22.2 No. 213)
Radiated and Conducted Emissions	EN50081-2 Class A
<i>Electrical /EMC:</i>	<i>The module has passed testing at the following levels:</i>
<ul style="list-style-type: none"> <li>• ESD Immunity (IEC61000-4-2)</li> </ul>	<ul style="list-style-type: none"> <li>• 4 kV contact, 8 kV air, 4 kV indirect</li> </ul>
<ul style="list-style-type: none"> <li>• Radiated Immunity (IEC61000-4-3)</li> </ul>	<ul style="list-style-type: none"> <li>• 10 V/m, 80 to 1000 MHz, 80% amplitude modulation, +900 MHz keyed carrier</li> </ul>
<ul style="list-style-type: none"> <li>• Fast Transient Burst (IEC61000-4-4)</li> </ul>	<ul style="list-style-type: none"> <li>• 2 kV, 5kHz</li> </ul>
<ul style="list-style-type: none"> <li>• Surge Immunity (IEC61000-4-5)</li> </ul>	<ul style="list-style-type: none"> <li>• 1 kV galvanic gun</li> </ul>
<ul style="list-style-type: none"> <li>• Conducted Immunity (IEC61000-4-6)</li> </ul>	<ul style="list-style-type: none"> <li>• 10 V, 0.15 to 80MHz<sup>(1)</sup></li> </ul>

(1) Conducted Immunity frequency range may be 150 kHz to 30 MHz if the Radiated Immunity frequency range is 30 MHz to 1000 MHz.

## Input Specifications

Specification	1769-IR6		
Input Types	100 $\Omega$ Platinum 385 200 $\Omega$ Platinum 385 500 $\Omega$ Platinum 385 1000 $\Omega$ Platinum 385 100 $\Omega$ Platinum 3916 200 $\Omega$ Platinum 3916	500 $\Omega$ Platinum 3916 1000 $\Omega$ Platinum 3916 10 $\Omega$ Copper 426 120 $\Omega$ Nickel 672 120 $\Omega$ Nickel 618 604 $\Omega$ Nickel-Iron 518	0 to 150 $\Omega$ 0 to 500 $\Omega$ 0 to 1000 $\Omega$ 0 to 3000 $\Omega$
Bus Current Draw (max.)	100 mA at 5V dc 45 mA at 24V dc		
Heat Dissipation	1.5 Total Watts (The Watts per point, plus the minimum Watts, with all points enabled.)		
Converter Type	Sigma-Delta		
Input Filtering	Low pass digital filter with programmable notch filter.		
Resolution	Input filter and configuration dependent. Refer to the 1769-IR6 User Manual, publication number 1769-UM005A-EN-P for more information.		
Common Mode Voltage Range	$\pm 10$ V dc maximum per channel		
Common Mode Rejection	110 dB minimum at 50 Hz with the 10 or 50 Hz filter selected 110 dB minimum at 60 Hz with the 10 or 60 Hz filter selected		
Normal Mode Rejection Ratio	70 dB minimum at 50 Hz with the 10 or 50 Hz filter selected 70 dB minimum at 60 Hz with the 10 or 60 Hz filter selected		
Non-linearity (in percent full-scale)	$\pm 0.05\%$		
Accuracy <sup>(1)</sup> at 25° C (°F)	$\pm 0.5^\circ\text{C}$ (0.9°F) for Pt 385 $\pm 0.4^\circ\text{C}$ (0.72°F) for Pt 3916 $\pm 0.2^\circ\text{C}$ (0.36°F) for Ni $\pm 0.3^\circ\text{C}$ (0.54°F) for NiFe $\pm 0.6^\circ\text{C}$ (1.08°F) for Cu	$\pm 0.15 \Omega$ for 150 $\Omega$ range $\pm 0.5 \Omega$ for 500 $\Omega$ range $\pm 1.0 \Omega$ for 1000 $\Omega$ range $\pm 1.5 \Omega$ for 3000 $\Omega$ range	
Accuracy <sup>(1)</sup> at 0 to 60° C (+32 to +140°F)	$\pm 0.9^\circ\text{C}$ (1.62°F) for Pt 385 $\pm 0.8^\circ\text{C}$ (1.44°F) for Pt 3916 $\pm 0.4^\circ\text{C}$ (0.72°F) for Ni $\pm 0.5^\circ\text{C}$ (0.9°F) for NiFe $\pm 1.1^\circ\text{C}$ (1.98°F) for Cu	$\pm 0.25 \Omega$ for 150 $\Omega$ range $\pm 0.8 \Omega$ for 500 $\Omega$ range $\pm 1.5 \Omega$ for 1000 $\Omega$ range $\pm 2.5 \Omega$ for 3000 $\Omega$ range	

(1) Accuracy is dependent upon the Analog/Digital converter output rate selection, excitation current selection, data format, and input noise.

Specification	1769-IR6
Accuracy Drift at 0 to 60° C (+32 to +140°F)	$\pm 0.026^{\circ}\text{C}/^{\circ}\text{C}$ ( $0.026^{\circ}\text{F}/^{\circ}\text{F}$ ) for Pt 385 $\pm 0.023^{\circ}\text{C}/^{\circ}\text{C}$ ( $0.023^{\circ}\text{F}/^{\circ}\text{F}$ ) for Pt 3916 $\pm 0.012^{\circ}\text{C}/^{\circ}\text{C}$ ( $0.012^{\circ}\text{F}/^{\circ}\text{F}$ ) for Ni $\pm 0.015^{\circ}\text{C}/^{\circ}\text{C}$ ( $0.015^{\circ}\text{F}/^{\circ}\text{F}$ ) for NiFe $\pm 0.032^{\circ}\text{C}/^{\circ}\text{C}$ ( $0.032^{\circ}\text{F}/^{\circ}\text{F}$ ) for Cu $\pm 0.007 \Omega/^{\circ}\text{C}$ ( $\pm 0.013\Omega/^{\circ}\text{F}$ ) for 150 $\Omega$ $\pm 0.023 \Omega/^{\circ}\text{C}$ ( $\pm 0.041\Omega/^{\circ}\text{F}$ ) for 500 $\Omega$ $\pm 0.043 \Omega/^{\circ}\text{C}$ ( $\pm 0.077\Omega/^{\circ}\text{F}$ ) for 1000 $\Omega$ $\pm 0.072 \Omega/^{\circ}\text{C}$ ( $\pm 0.130\Omega/^{\circ}\text{F}$ ) for 3000 $\Omega$
Repeatability <sup>(1)</sup>	$\pm 0.01^{\circ}\text{C}$ ( $0.018^{\circ}\text{F}$ ) for Ni and NiFe $\pm 0.2^{\circ}\text{C}$ ( $0.36^{\circ}\text{F}$ ) for other RTD inputs $\pm 0.04 \Omega$ for 150 $\Omega$ resistances $\pm 0.2 \Omega$ for other resistances
Open-Circuit Detection Time <sup>(2)</sup>	6 ms to 303s
Channel Update Time	Input filter and configuration dependent. Refer to the 1769-IR6 User Manual, publication number 1769-UM005A-EN-P.
Input Channel Configuration	via configuration software screen or the user program (by writing a unique bit pattern into the module's configuration file). Refer to your controller's user manual to determine if user program configuration is supported.
Calibration	The module performs autocalibration on channel enable and on a configuration change between channels. You can also program the module to calibrate every five minutes.
Module OK LED	On: module has power, has passed internal diagnostics, and is communicating over the bus. Off: Any of the above is not true.
Channel Diagnostics	Over- or under-range or broken input by bit reporting
Maximum Overload at Input Terminals	Voltage: $\pm 30\text{V}$ dc continuous, $\pm 20$ mA Current: $\pm 20$ mA continuous, $\pm 30\text{V}$ dc
Cable Impedance Max.	25 $\Omega$
Input Impedance	>10 M $\Omega$
Power Supply Distance Rating	8 (The module may not be located more than 8 modules away from the system power supply.)
Channel to Bus Isolation	720V dc for 1 minute, optical and magnetic (qualification) 30V ac/30V dc working voltage (IEC Class 2 reinforced insulation)
Channel to Channel Isolation	$\pm 10\text{V}$ dc
Vendor I.D. Code	1
Product Type Code	10
Product Code	37

(1) Repeatability is the ability of the module to register the same reading in successive measurements for the same input signal.

(2) Open-circuit detection time is equal to channel update time.

## Hazardous Location Considerations

This equipment is suitable for use in Class I, Division 2, Groups A, B, C, D or non-hazardous locations only. The following WARNING statement applies to use in hazardous locations.

### WARNING



#### EXPLOSION HAZARD

- Substitution of components may impair suitability for Class I, Division 2.
- Do not replace components or disconnect equipment unless power has been switched off.
- Do not connect or disconnect components unless power has been switched off.
- This product must be installed in an enclosure.
- All wiring must comply with N.E.C. article 501-4(b).

## Environnements dangereux

Cet équipement est conçu pour être utilisé dans des environnements de Classe 1, Division 2, Groupes A, B, C, D ou non dangereux. La mise en garde suivante s'applique à une utilisation dans des environnements dangereux.

### AVERTISSEMENT



#### DANGER D'EXPLOSION

- La substitution de composants peut rendre cet équipement impropre à une utilisation en environnement de Classe 1, Division 2.
- Ne pas remplacer de composants ou déconnecter l'équipement sans s'être assuré que l'alimentation est coupée.
- Ne pas connecter ou déconnecter des composants sans s'être assuré que l'alimentation est coupée.
- Ce produit doit être installé dans une armoire.

## For More Information

For	Refer to this Document	Pub. No.
Detailed information on installing, programming, and troubleshooting your Compact RTD/resistance Input module.	Compact RTD/resistance Input Module User Manual	1769-UM005A-EN-P
A more detailed description of how to install and use your Compact I/O with MicroLogix 1500 programmable controller.	MicroLogix 1500 Programmable Controllers User Manual	1764-UM001A-US-P
Detailed information on programming your MicroLogix System	MicroLogix 1200 and MicroLogix 1500 Instruction Set Reference Manual	1762-RM001B-US-P
A detailed description on how to install and use your Compact I/O with the 1769-ADN DeviceNet Adapter.	1769-ADN DeviceNet Adapter User Manual	1769-UM001A-US-P
An overview of the MicroLogix 1500 system, including Compact I/O.	MicroLogix 1500 System Overview	1764-SO001B-EN-P
More information on proper wiring and grounding techniques.	Industrial Automation Wiring and Grounding Guidelines	1770-4.1

If you would like a manual, you can:

- download a free electronic version from the internet:  
**[www.ab.com/micrologix](http://www.ab.com/micrologix)** or **[www.theautomationbookstore.com](http://www.theautomationbookstore.com)**
- purchase a printed manual by:
  - contacting your local distributor or Rockwell Automation representative
  - visiting **[www.theautomationbookstore.com](http://www.theautomationbookstore.com)** and placing your order
  - calling 1.800.963.9548 (USA/Canada)  
or 001.330.725.1574 (Outside USA/Canada)

### For More Information

Product Line	Product Description	Product Reference
MicroLogix	MicroLogix 1500 Programmable Logic Controller	1756-0146
Compact	Compact 1756 Programmable Logic Controller	1756-0147
PowerFlex	PowerFlex 7000 AC Drive	1756-0148
Reliance	Reliance Electric Power Transmission Components	1756-0149
Allen-Bradley	Allen-Bradley Control Systems	1756-0150
Dodge	Dodge Mechanical Power Transmission Components	1756-0151
Rockwell Software	Rockwell Software Control Systems	1756-0152

MicroLogix and Compact are trademarks of Rockwell Automation.  
Belden is a trademark of Belden, Inc.

#### Reach us now at [www.rockwellautomation.com](http://www.rockwellautomation.com)

Wherever you need us, Rockwell Automation brings together leading brands in industrial automation including Allen-Bradley controls, Reliance Electric power transmission products, Dodge mechanical power transmission components, and Rockwell Software. Rockwell Automation's unique, flexible approach to helping customers achieve a competitive advantage is supported by thousands of authorized partners, distributors and system integrators around the world.

**Americas Headquarters**, 1201 South Second Street, Milwaukee, WI 53204, USA, Tel: (1) 414 382-2000, Fax: (1) 414 382-4444  
**European Headquarters SA/AV**, avenue Hermance Debroux, 46, 1160 Brussels, Belgium, Tel: (32) 2 663 06 00, Fax: (32) 2 663 06 40  
**Asia Pacific Headquarters**, 27/F Citicorp Centre, 18 Whitfield Road, Causeway Bay, Hong Kong, Tel: (852) 2897 4788, Fax: (852) 2508 1846



**Rockwell Automation**

Publication 1769-IN027A-EN-P - February 2001

PN 40072-098-01(A)

© 2001 Rockwell International Corporation. Printed in the U.S.A.